

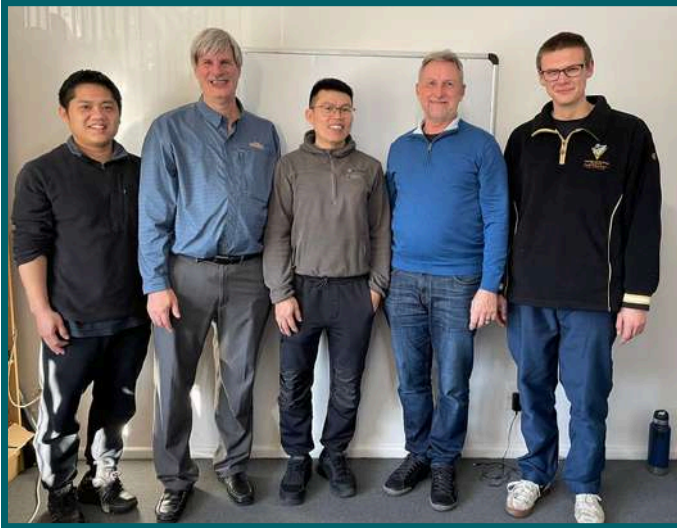

# shark SEATING



# 2025 Brochure



The formation of Shark Seating happened at a time when the NZ Navy faced delays and rising costs from inflexible suppliers dominating a small market. There was a need for agile and cooperative suppliers offering lighter, more adaptable products and services.

At Shark Seating, our passion is deeply rooted in our mission: to significantly reduce the number of people affected by spinal injuries on boats. Central to our success is a customer-centric approach that drives our strategies for maintaining and expanding our international client base.

We recognise that our mission remains critical as long as there are customers who lack adequate protection from wave impacts. This drives our continuous efforts to innovate and improve our products, ensuring they remain accessible to all who need them.



## WARRANTY & SERVICE

All shark equipment includes a **3-year global manufacturer's warranty**. To register your product and receive service updates:

1. **Scan the QR code:** Use the QR code provided to easily complete your product registration and sign up for important service updates.
2. **After warranty period:** If your product is beyond the warranty period, please contact us directly for assistance with replacement parts.





## Lightweight

All shark suspensions are designed to be extremely lightweight, enhance handling, improve fuel efficiency, and reduce the overall weight of your boat.



## Low Cost

Shark suspensions are priced to ensure that everyone can experience ultimate comfort and safety, regardless of their budget.



## Performance

Each suspension offers extensive travel, providing a smooth and safe ride.



## Non-corrosive

Shark parts are built to endure the harsh marine environment, guaranteeing your suspensions will stand the test of time.



## Waterproof

Shark seats and foams are designed specifically for the water. You'll never have to worry about sitting on a wet seat or seeing damage, even from saltwater exposure.



## UV Resistant

Shark seating's injection-moulded proprietary plastic blend is UV-protected to ensure your seats remain unaffected by harsh UV rays, no matter where in the world you are.



## Scratch Resistant

With shark seats in demanding and harsh environments, scratch resistance is crucial to ensure your seat remains in pristine condition.



## No Pinch Points

Shark suspensions enhance safety by eliminating pinch points, hard surfaces and sharp edges preventing injury to fingers or arms even if passengers or hands are under the seat.



## Simplicity

Shark suspensions are self adjusting, ensuring easy maintenance and consistent comfort. The shock absorbers automatically adapt to your weight, so there's no need to manually adjust settings for the perfect ride.



## Environmental Care

Our injection moulding process utilises carbon sequestration to strengthen our bioplastic leaf springs and promote sustainable production of FLEXANITE composite.



## Worldwide Shipping

Shark operates a warehouse in Brussels for efficient distribution in Europe, while operations in New Zealand, the USA, and Taiwan manage global logistics.

NATO# NSN 2540-98-209-0174



CAD here

Shark# FXAXAA00



## All purpose shock mitigation

**FLEX** provides 225mm of ultra-smooth travel that is completely corrosion-proof, light, and tough. Combined with our stainless steel shock absorber, there are no pinch points or sharp edges and it will withstand 10g impacts making it safe in every way.

*Simply Smooth*

Weight	Impact protection	Weight capacity	Travel
<b>9kg</b> 19.8lbs	<b>10G</b>	<b>120kg</b> 265lbs	<b>225mm</b> 9"



# FLEXpod

NATO# NSN 2540-98-209-0145



CAD here

Shark# PXEXAA00



## For serious weight saving

2/3rd the performance of *FLEX*, 1/3rd the weight and 1/2 the height. *FLEXpod* delivers industry leading travel in an extremely compact size, saving your back, space and money all at once.

### *Simply Smooth*

Weight

Impact protection

Weight capacity

Travel

**3.3kg**  
7.3lbs

**6G**

**100kg**  
220lbs

**150mm**  
6"

NATO# NSN 2540-98-209-0174



CAD here

Shark# FXDXAA00



## Crash tested shock mitigation

Made for harsh conditions and maximising weight capacity for heavy passengers and extra equipment. **FLEX-HD** lifts the max weight capacity to 140kg and is fitted with a heavy-duty shock absorber. Available complete or as an upgrade.

*Simply Smooth*

Weight

Impact protection

Weight capacity

Travel

**10kg**  
22lbs

**10G**

**140kg**  
309lbs

**225mm**  
9"





# FLEXpod-HD

NATO# NSN 2540-98-209-0145



CAD here

Shark# PFXAA00



## Toughened weight saving

HD stands for heavy-duty. 2 alloy plates are added to stiffen the suspension to allow for approved 3rd party seats. Available complete or as an upgrade kit. Contact us for approved seats.

### *Simply Smooth*

Weight	Impact protection	Weight capacity	Travel
<b>4.3kg</b> 9.5lbs	<b>6G</b>	<b>100kg</b> 220lbs	<b>150mm</b> 6"



CAD here

Shark# PBEX2000



## The most lightweight suspension seat

Featuring 150mm of suspension travel, this compact design fits effortlessly into even the tightest spaces.

*Simply Smooth*

Weight

Impact protection

Weight capacity

Travel

**7.1kg**  
15.7lbs

**6G**

**100kg**  
220lbs

**150mm**  
6"





CAD here

## EVOlite

Shark# PGEX0000-T



Shark# FGAX0000-T



## Lightweight helm seat

**EVO** is sharks helm seat that is light weight, customisable and comfortable. You can choose between **EVO** and **EVOlite** depending on the level of protection required.

### EVO

Total weight

Suspension travel

Weight capacity

18.5kg/40.8lbs

225mm/9"

120kg/265lbs

### EVOlite

Total weight

Suspension travel

Weight capacity

8kg/17.6lbs

150mm/6"

100kg/220lbs



**More info**

Shark# FBAX2000



## The starting point for any jockey seat

**ULTRA** is the flagship model, adaptable and reliable for both recreational and military markets. Users can customise it with upgrades from our modular system or keep it simple.

*Simply Smooth*

Weight	Impact protection	Weight capacity	Travel
<b>13.1kg</b> 28.8lbs	<b>10G</b>	<b>120kg</b> 265lbs	<b>225mm</b> 9"



More info

Shark# FEAX1000-G



## Upholstered leather-like finish

**EPIC** is our upholstered jockey seat with a rear grab handle. Available in 4 colours so you can match the style of your boat.

Custom colours available per request.

*Simply Smooth*

Weight

Impact protection

Weight capacity

Travel

**14.1kg**  
31.1lbs

**10G**

**120kg**  
265lbs

**225mm**  
9"



More info

Shark# FEAX1110-G



## Comfortable jockey-based helm seat

The most complete seat that features **EPIC** upholstery, a rear handle, arm rests and a high-back attachment. The benefits of a jockey seat with helm seat features.

*Simply Smooth*

Weight

Impact protection

Weight capacity

Travel

**16.1kg**  
35.5lbs

**10G**

**120kg**  
265lbs

**225mm**  
9"

## Cordura

Upgrade and lengthen the life of your ULTRA. Our elastic fit design supports effortless installation.

## EASY-FIT

Styling your seat has never been easier. Simply fit and tighten to achieve a fully upholstered look.



Scan for installation video



Custom upholstery available per request



## WITH STORAGE OPTIONS

### FIX (plastic)

Shark# FXXBAA00

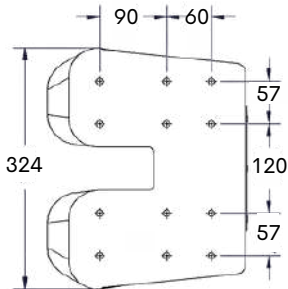
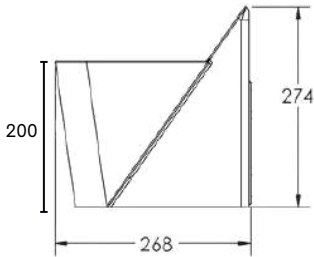

Base

Fastenings

### A1

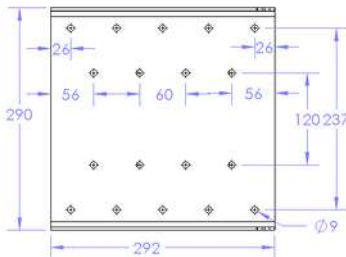
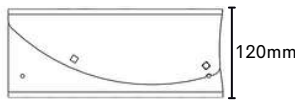
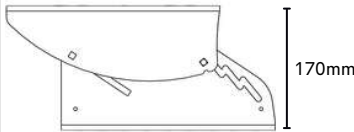

Base

Fastenings

### TRAX

Suspensions can be mounted with adaptor plate or directly

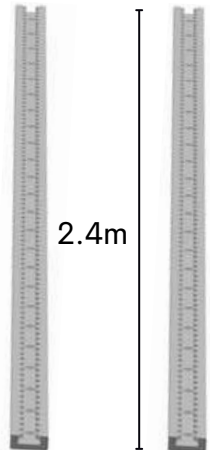
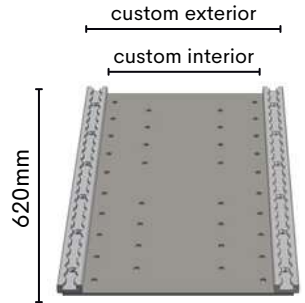

Fastenings

M8 x 8, 316 SS

Weight

2.8kg / 6.2lbs

M8 x 8, 316 SS

Weight

3.2kg / 7lbs

M8 x 8, 316 SS

Weight

3.4kg / 7.5lbs



## MOVEMENT IN ALL DIRECTIONS



Shark# FXXCAA03

**A1** (alloy)  
Height adjustable

Shown directly mounted to TRAX  
Adaptor plate available for wider spacings



Shark# FXXCAA04

**A2** (alloy)  
Height adjustable

Shown with adaptor plate mounted to TRAX



Shark# FXXCAA05

**A3** (alloy)  
Height adjustable

Shown with adaptor plate mounted to TRAX



Bolt spacing is same across range

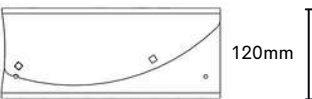
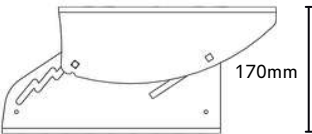
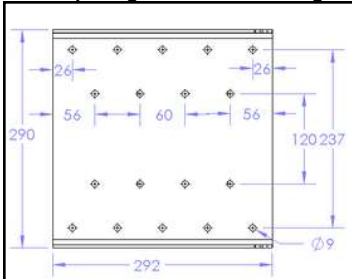

**Fastenings**

**M8 x 8, 316 SS**

**Weight**

**3.2kg/7lbs**

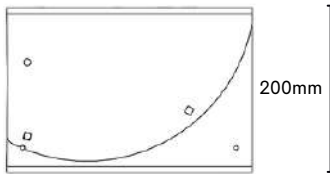
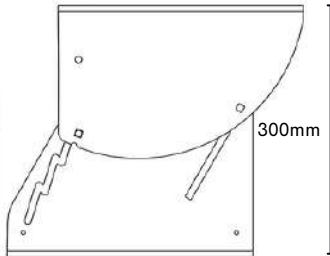

**Fastenings**

**M8 x 8, 316 SS**

**Weight**

**4kg/8.7lbs**

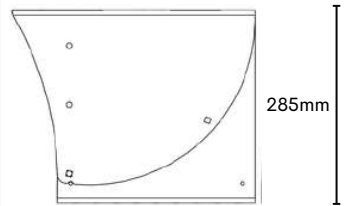
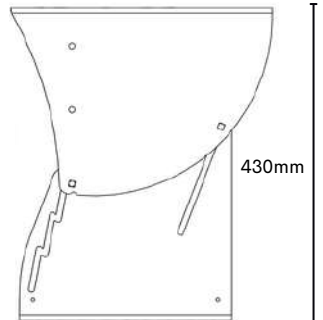

**Fastenings**

**M8 x 8, 316 SS**

**Weight**

**5.2kg/11.5lbs**

## RESTRAINTS AND GRIPS

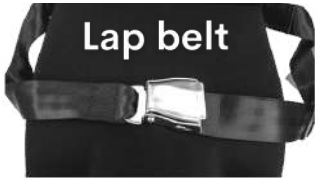

## Fore-handle



## Folding foot-rest



## Foldable foot pegs

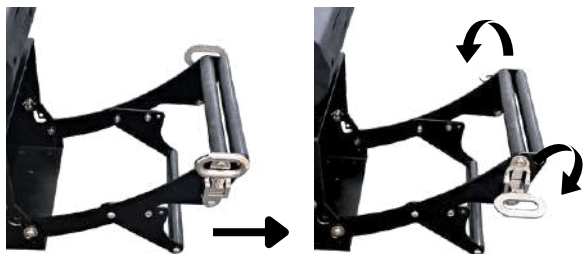

## SWIVEL, TILT & HEIGHT ADJUSTMENT

(More info on movement page)



Swivel allows for layout modification like a stretcher, bench and more.



**TILT** feature permits each seat to pitch forward and aft in unique space requirements.

## BASKET

Extra storage at the rear that fits perfectly with our rear handle.

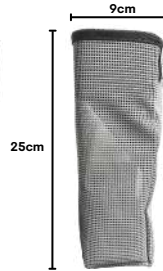

## 4-POINT-HARNESS, HEAD REST



## ARM REST

## TRAX

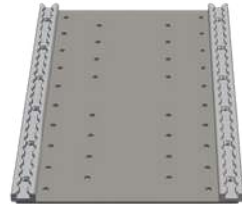

Enables you to mount, fully remove, and slide any shark suspension system using an adaptor plate or directly onto the plinth in recent models. Custom widths available.

<p><b>Rear Grip</b> Shark# FXXX3000</p> 	<p><b>Side handles (pair)</b> Shark# FXXX2000</p> 
<p><b>Evo Headrest</b> Shark# FXXX0101</p> 	<p><b>High back</b> Shark# FXXX0100</p> 
<p><b>Fore-handle</b> Shark# FXXXAA10</p> 	<p><b>Arm rest (pair)</b> Shark# FXXX1011</p> 
<p><b>Cordura Cover</b> Shark# FCXXAD02</p> 	<p><b>Swivel</b> Shark# XXXBA00</p> 
<p><b>Easy-Fit Cover</b> Shark# FXXXAD04</p> 	<p><b>TILT</b> Shark# FXXC0020</p> 
<p><b>Basket</b> Shark# FXXXAB01</p> 	<p><b>Lap Belt</b> Shark# FXXX0001</p> 
<p><b>4 Point Harness</b> Shark# FXXXAB01</p> 	<p><b>HD straps</b> Shark# FXXX0006</p> 
<p><b>TRAX</b> Shark# FXXXAA25 (Vertical sides)  Shark# FXXXAA24 (Chamfered sides)</p> 	<p><b>Adaptor plate</b> Shark# FXXXAA06</p> 
<p><b>Folding footrest</b> Shark# XXXAA02</p> 	<p><b>Foot-rest</b> Shark# FXXXAA02</p> 





**"As manufacturer of high speed indestructible HDPE workboats we rely on a reliable, safe and economical product like shark ULTRA suspension seats to keep our customers safe and healthy. When working in a rough environment at high speeds a comfortable and practical jockey seat is a must have for any high speed boat operator. We have been using shark Ultra seats for all our open workboats for the last 3 years and we did not have any problems or service issues at all. It is a good and practical seat for a reasonable price!"**

**Bruno Tideman  
Tideman Boats BV**



**"Went out in 1m swells, which for the lake is rough. Brilliant is all I can say. Forty knots head-on and we were all comfortable. Even full speed at 48 knots with no problems. Usually we are doing 30 knots and really hurting"**

**Alan Turia  
Turangi Coast Guard, NZ**



**"The jockey seat has been brilliant... I would never have thought of getting such a seat before, but now I would not want to give it up even if I was in perfect health .. it is just so much safer and more comfortable than standing or sitting in anything else."**

**Michael Halsey  
Sunshine Coast, AU**



# NATO Codes



Scan for codes

**ALL CODES ARE PREFIXED WITH: NSN**

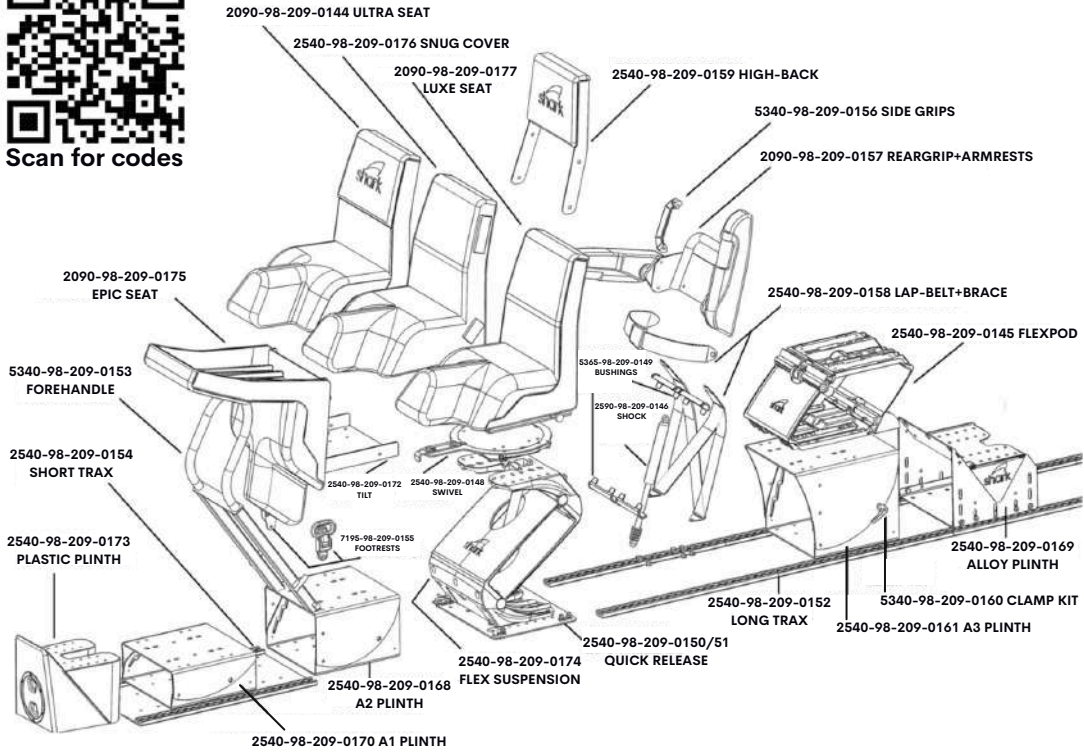

Defence customers like the modularity of the shark seating system because they can customize the seats to suit any mission while maintaining NATO compliance. Swapping seat types, accessories, mount heights, restraints and track systems can be performed easily and without ever deviating from the NATO catalog.

The benefits of a modular system apply equally to dealers and boat operators who can easily upgrade or customize their seating to suit changing requirements or when moving seats from one boat to another. Whatever your need, the shark modular system has a configuration which will suit it